

A: P.X. 545000, No.38, 7 Row Industry zone,
6-1 Jiutoushan Road, Yufeng district, Liuzhou
city, Guangxi province, China.
M: +86 186 021 756 88
E: info@alumsolar.com
W: www.alumsolar.wixsite.com/alumsolar



ALUMSOLAR

Solar mounting system



FROM 2012 ALUMSOLAR





2012

Incorporation of Alumsolar

Being awarded as mounting system supplier and solution provider for 20MW Grounded Solar Farm in Qinghai, 20MW Solar System for roofs in Australia and 4MW Grounded solar farm in Japan.

2013

Obtained ISO9001 and annual volume reaches 80MW

explored Counter Weighed aluminum mounting system for America

2014

obtained CE certification, and Japan branch office is incorporated in Kobe

developed solar mounting system market in UK and annual volume hits 100MW

2015

obtained CSA certification for North America

2016

Solar PV System integration division is incorporated and signed supply agreements with many domestic EPCs. Annual volume hits 160MW

Singapore branch office is incorporated and explored South Asia market with annual volume 20MW

2017

annual volume hits 240MW and developed Middle East and South America Markets



“TOP WORKMANSHIP
RELIABLE PERFORMANCE
PROFESSIONAL ENGINEERING.”



Company Profile	(p07-08)
Metal Roof Solution	(p09-14)
Tile Roof Solution	(p15-18)
RC Roof Solution	(p19-24)
Ground Mounted Solar Racking	(p25-30)
Solar Carport Solution	(p31-32)
Other Applications	(p33-34)
Professionalism	(p35-36)
Project References	(p37-40)
Product Datasheet	(p41-42)



Mounting System Solution Provider Alumsolar

Alumsolar Pv Engineering Co.,Ltd, was established in 2012, with a registered capital of RMB 2 million, focusing on the development and fabrication of solar mounting system with value added technical services

company profile



Quality is our culture in Alumsolar.

Alumsolar Pv Engineering Co.,Ltd was established in 2015, with a registered capital of RMB 2 Million, focusing on the development and fabrication of solar PV mounting systems with value added technical services.

Provides all kinds of solar mounting bracket in Alumsolar. One of market leader for solar mounting structure Since 2000. With 2 factories 5000 workers and more that 10000 solutions, Professional produce and design, ensure that the best solutions suit to each clients' projects.

High-quality, innovative, strong and extremely flexible in terms of application – these are the features of the ALUMSOLAR' s PV mounting systems. Whether you need steel or high-strength aluminum, an individual mounting profile or a small fastening screw – everything we offer has to meet requirements that are not merely high, but the very highest.

Designed for a service life of at least 25 years of perfect functionality, even in extreme conditions. For flat roofs, pitched roofs, solar parks and carports. For large scale solar farms, we can also take care of designing, calculating and supervising complete solar and photovoltaic plants. From the soil investigation and calculation of all structural analyses to site design, logistics and a version which is ready to release and transfer to the customer. The company has built a strong manufacturing capacity and complete industrial chain system, after years of accumulation and precipitation, with research and innovation as a source of power, and constantly promotes product upgrading; we gather a wide range of customer resources at domestic and abroad.

In China, we work closely China State Power, Huaneng Energy, Zhonghang Power, CSIC, Trina Solar, Canadian Solar, etc. Overseas, our mounting systems are installed for IKEA, Pepsi, etc., we have customers worldwide, including Japan, Singapore, Philippine, Indonesia, India, Middle East, North and South America, etc. At present the company' s annual production of 500MW solar racking capacity, and provide design and development, as well as some customized technical services for domestic and oversea customers.



CE Certificate



ISO 9001 Certificate



CE Certificate

ISO9001

As the international standard that specifies requirements for a quality management system (QMS). Organizations use the standard to demonstrate the ability to consistently provide solar mounting structure products and services that meet customer and regulatory requirements.

CE marking with European standard

CE marking is a certification mark that indicates conformity with health, safety, and environmental protection standards for solar mounts sold within the European Economic Area. The CE marking is also found on solar mounts sold outside the EEA that are manufactured solar mounts in, or designed to be sold in, the EEA.

GSA

CSA International (Canadian Standards Association), a member of the CSA Group, is a provider of solar mounts testing and certification services for electrical, a variety of other products. Recognized in the U.S., Canada and around the world.



Patent for Fast Installation Mounting System



Patent for Wind Load Reducing Mounting System



Patent for Leakage Free Mounting System

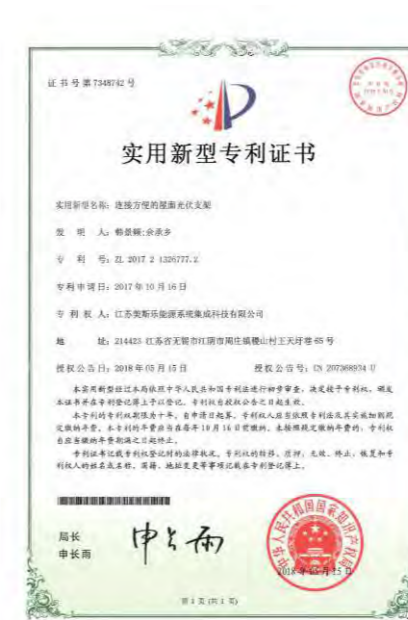

Patent for Easy Connection Mounting System



Patent for Quick Installation Mounting System

Alumsolar is Certified and Honored!

Metal Roof Solution M2

Module has angles to the Roof Profile 5° / 10° / 15°

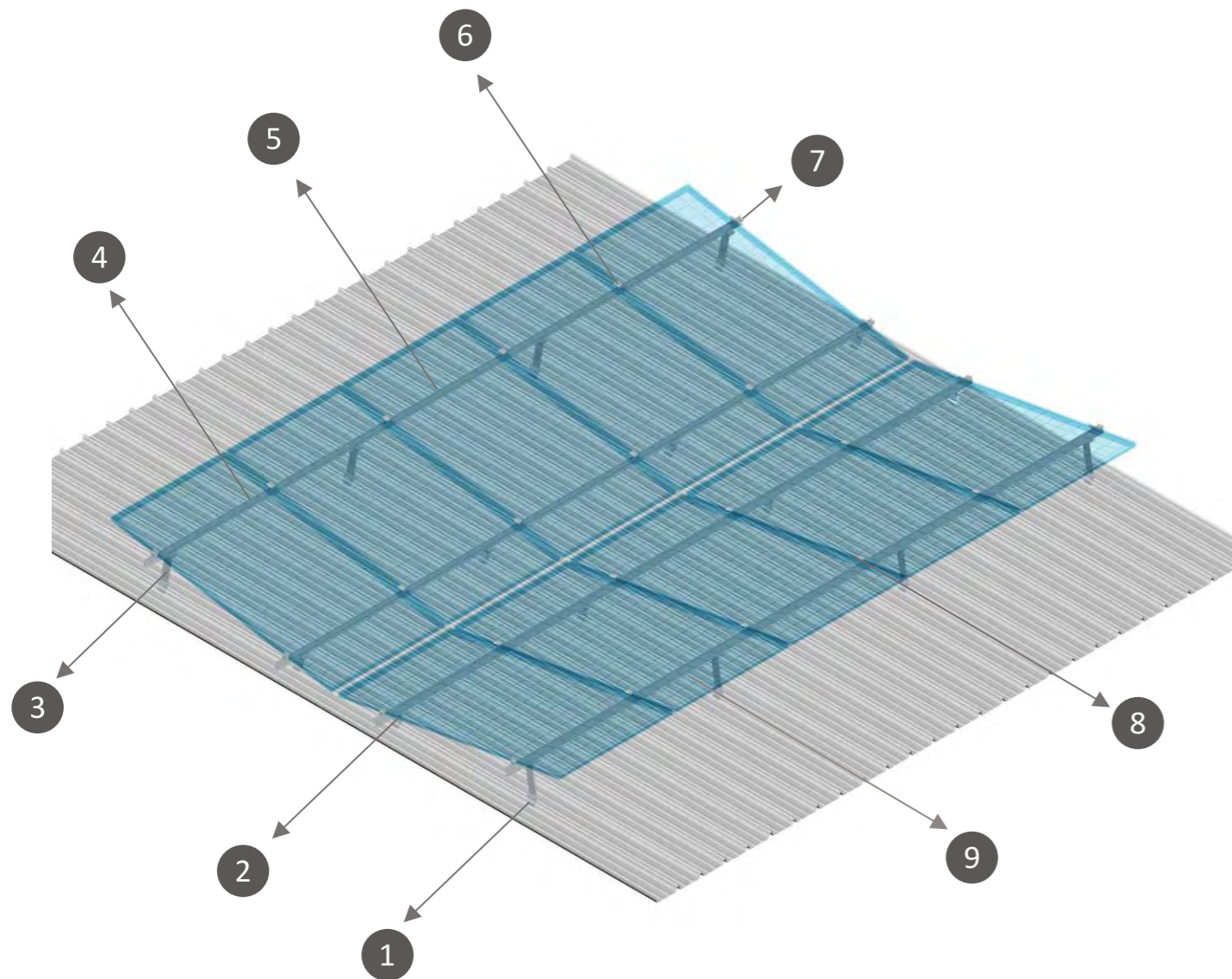

- | | | | | | |
|---|--|---------------|---|--|---------------|
| 1 | | Fixation Part | 2 | | L Feet |
| 3 | | Rail | 4 | | Rail Joiner |
| 5 | | Mid Clamp | 6 | | End Clamps |
| 7 | | Weed Washer | 8 | | Grounding Lug |
| 9 | | Solar Module | | | |



Tile Roof Solution

Module follow Roof Profile 0°

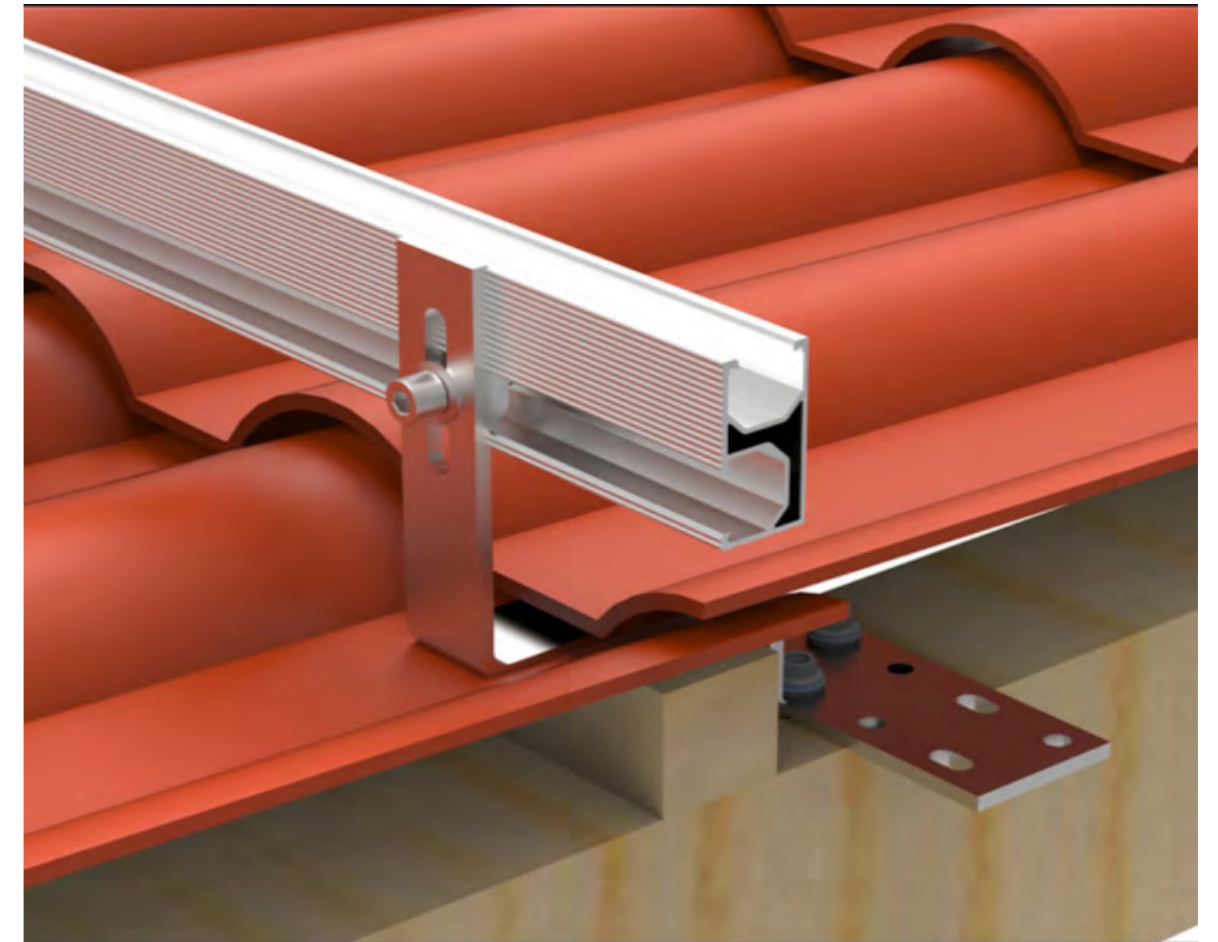
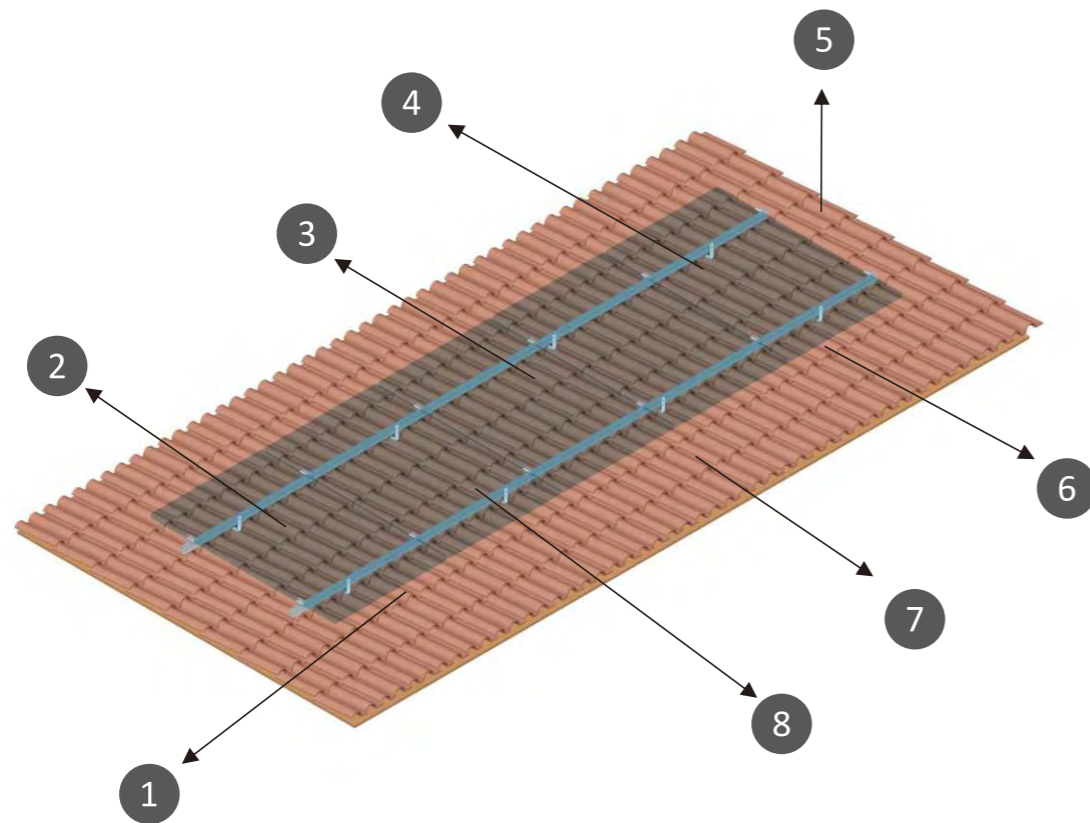

- | | | | | | |
|---|--|---------------|---|--|--------------|
| 1 | | Hook | 2 | | Rail |
| 3 | | Rail Joiner | 4 | | Mid Clamp |
| 5 | | End Clamps | 6 | | Weed Washer |
| 7 | | Grounding Lug | 8 | | Solar Module |



Metal Roof Solution M1

Module follow Roof Profile 0°

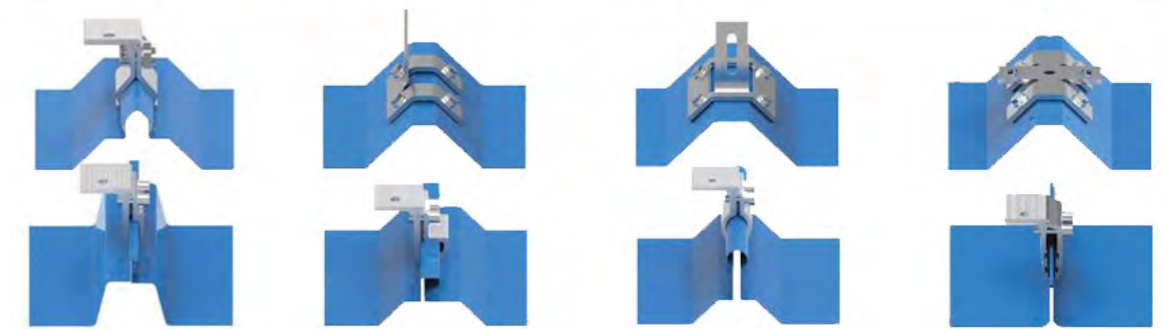
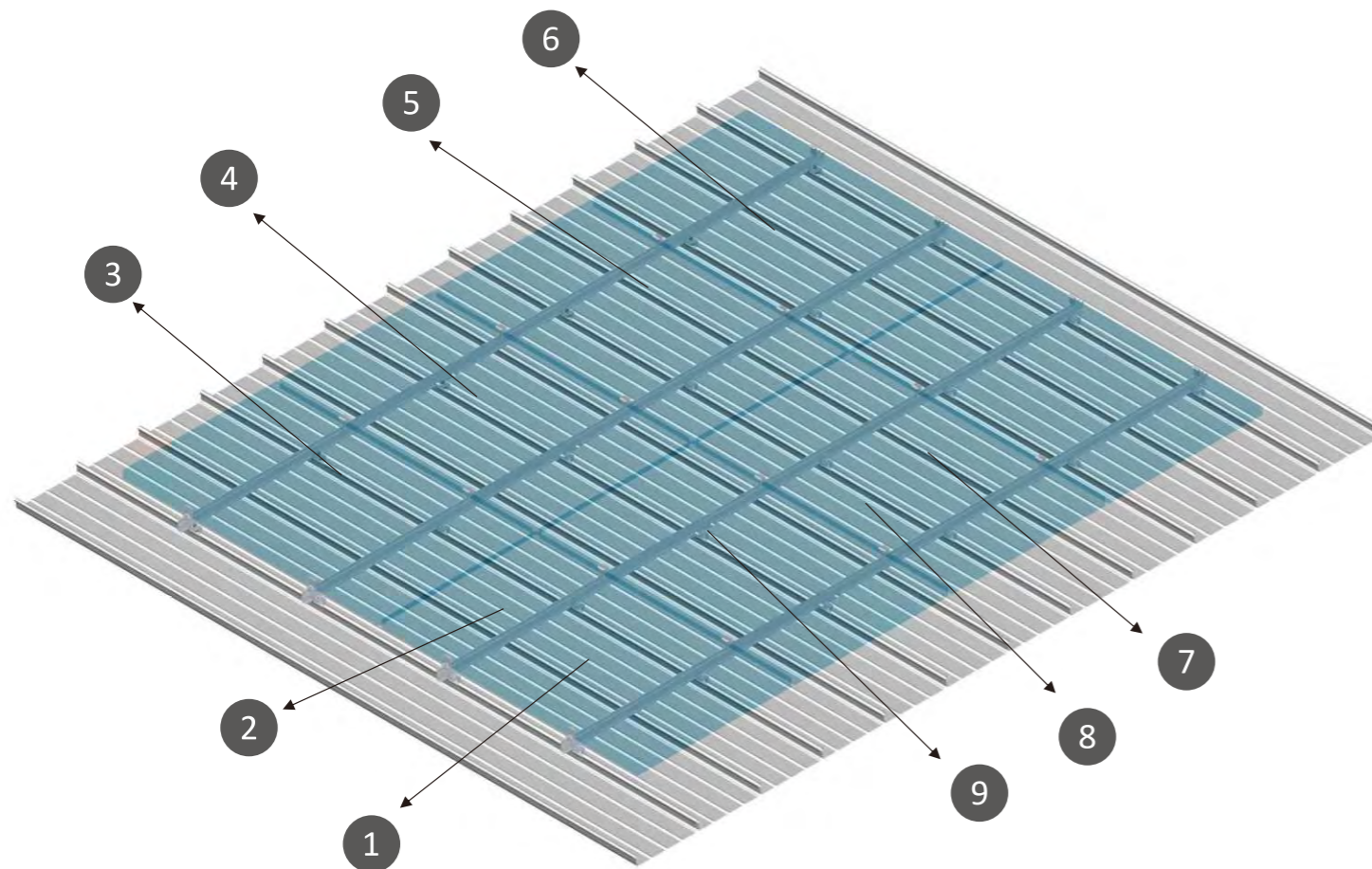

- | | | | | | |
|---|--|---------------|---|--|---------------|
| 1 | | Fixation Part | 2 | | L Feet |
| 3 | | Rail | 4 | | Rail Joiner |
| 5 | | Mid Clamp | 6 | | End Clamps |
| 7 | | Weed Washer | 8 | | Grounding Lug |
| 9 | | Solar Module | | | |

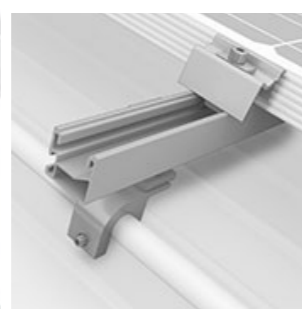

Seam Clamp

Rail with Cable Tray

Standing Seam Type



Metal Roof Solution M2

Module follow Roof Profile 0° Thin solar panels installation

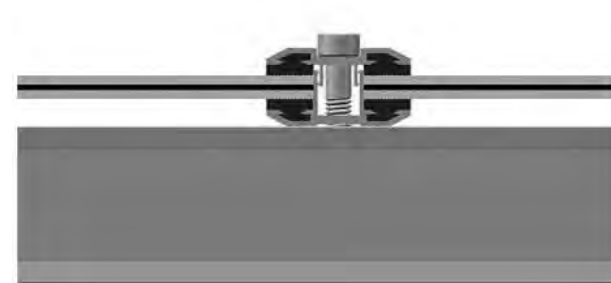
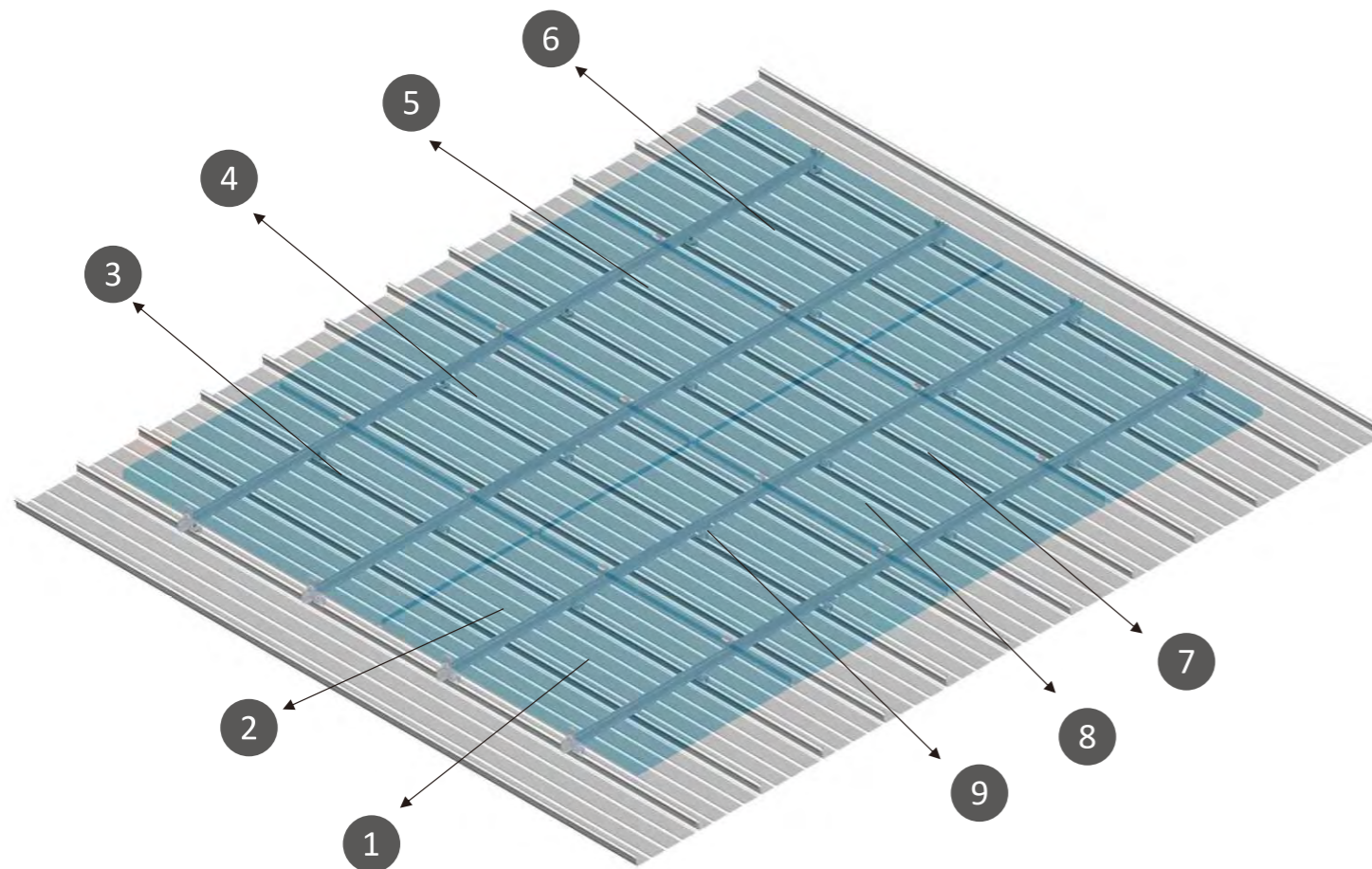

Mid/inter clamp fixed thin solar panels

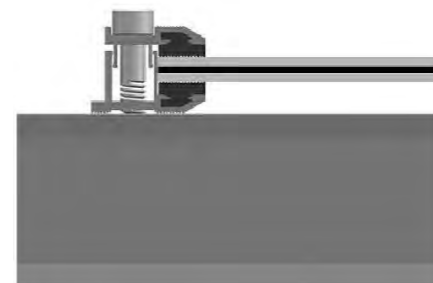

End clamp fixed thin solar panels

- | | | | | | |
|---|--|---------------|---|--|---------------|
| 1 | | Fixation Part | 2 | | L Feet |
| 3 | | Rail | 4 | | Rail Joiner |
| 5 | | Mid Clamp | 6 | | End Clamps |
| 7 | | Weed Washer | 8 | | Grounding Lug |
| 9 | | Solar Module | | | |



Metal Roof Solution

Simple Installation Process

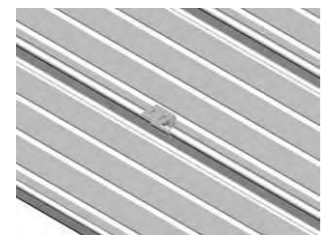

Step 1:
Identify the location for the 1st clamps as specified in the drawing and fix the clamp on the metal roof

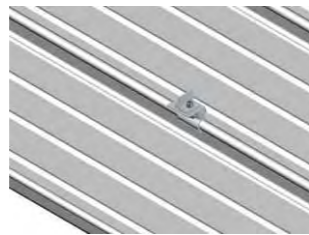

Step 2:
Mount the rail clip on the seam clamp (not tighten)



Step 3:
Repeat the process and spread the fixation parts all over the roof with locations as specified in the drawing



Step 4:
Secure the rails on the seam clamp and tighten the rail clip



Step 5:
connect the rails and repeat the process, lay all the rails on the roof

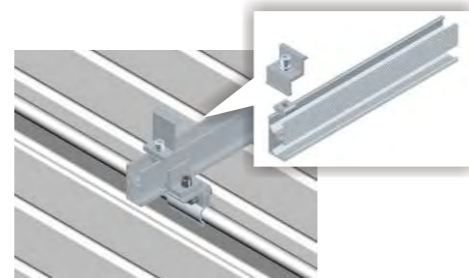

Step 6:
Fix the 1st end clamp as location specified in the drawing and do not tighten it

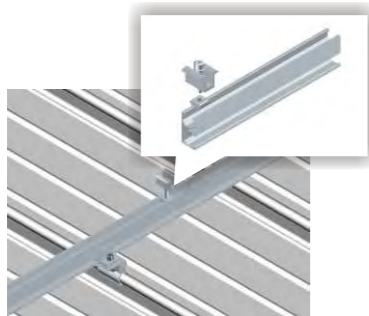

Step 7:
Fix the 1st Mid clamp with weed washer as location specified in the drawing and do not tighten it

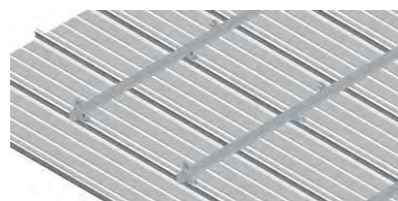

Step 8:
Fix all the other mid and end lamps for the 1st module installation

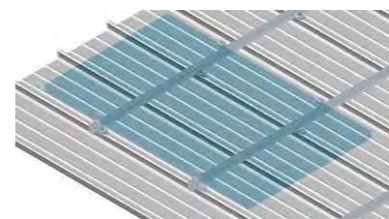

Step 9:
Mount the 1st Module on the rail and tighten the mid and end clamps.

Step 10:
repeat the process and complete all installations.

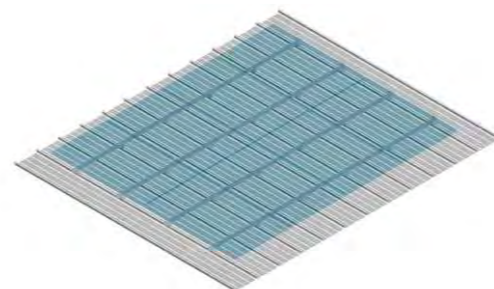

<M1>

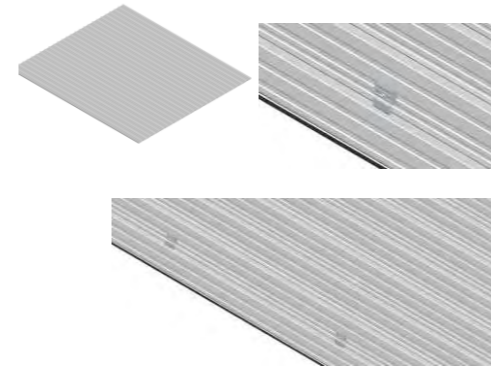

Step 1:
Identify the location for the front leg as specified in the drawing and fix the clamp on the metal roof
Identify the location for the rear leg as specified in the drawing and fix the clamp on the metal roof

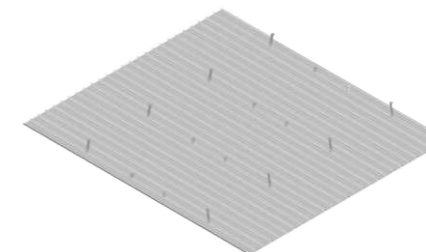

Step 4:
Repeat the process and spread the fixation parts all over the roof with locations as specified in the drawing

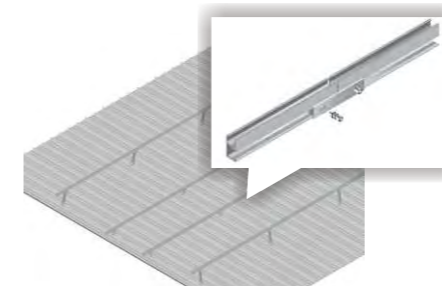

Step 7:
Repeat the process and spread it over for all the legs on the roof



Step 2:
Fix the front leg on the seam clamp



Step 5:
Fix the rail clip on the front leg but not tighten it

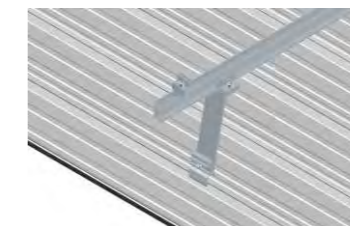

Step 8:
Fix the 1st end clamp as location specified in the drawing and do not tighten it

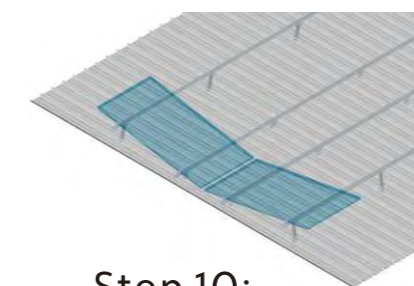

Step 10:
Mount the 1st Module on the rail and tighten the mid and end clamps.

<M2>

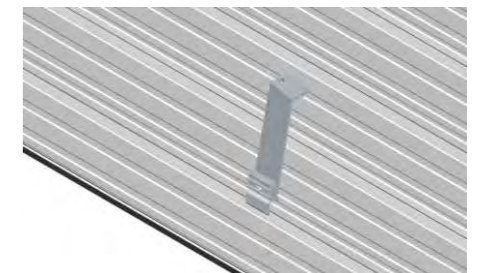

Step 3:
Fix the rear leg on the seam clamp

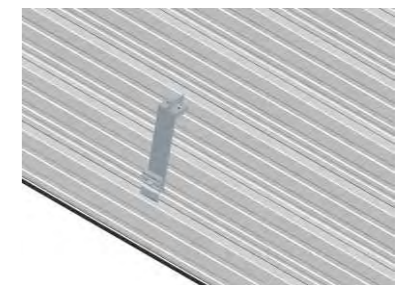

Step 6:
Fix the rail clip on the rear leg but not tighten it



Step 9:
Fix the 1st Mid clamp with weed washer as location specified in the drawing and do not tighten it

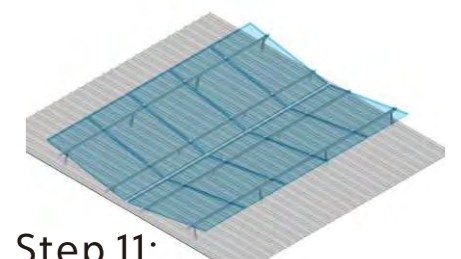

Step 11:
repeat the process and complete all installations.

Tile Roof Solution

Simple Installation Process

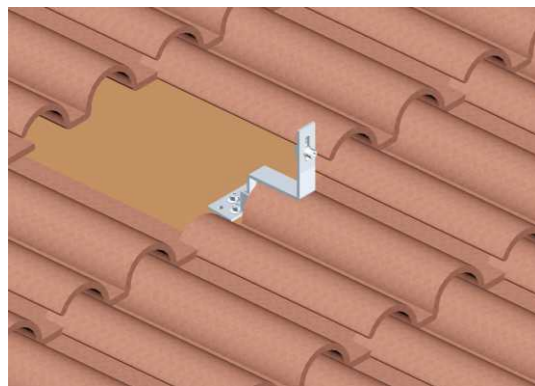

Step 1:
Identify the 1st hook location as specified in the drawing, remove a few pieces of tiles and mount 1st hook



Step 2:
Re-instate the Tiles

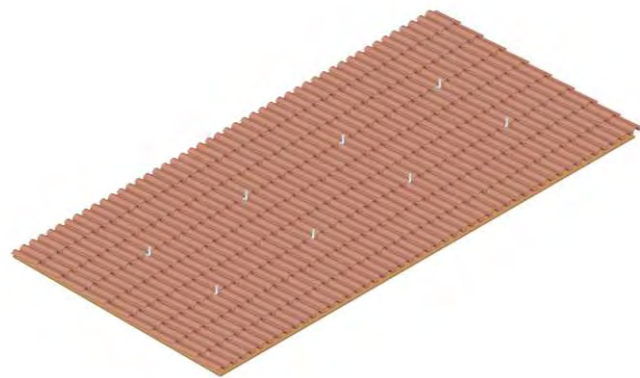

Step 3:
Mount all the hooks with spacing as specified in the drawing with good alignment



Step 4:
Secure the rail on the hooks

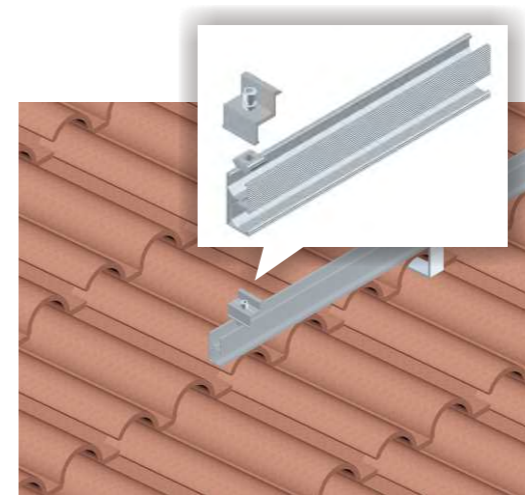

Step 5:
Fix the 1st end clamp but not tighten at location as specified in the drawing

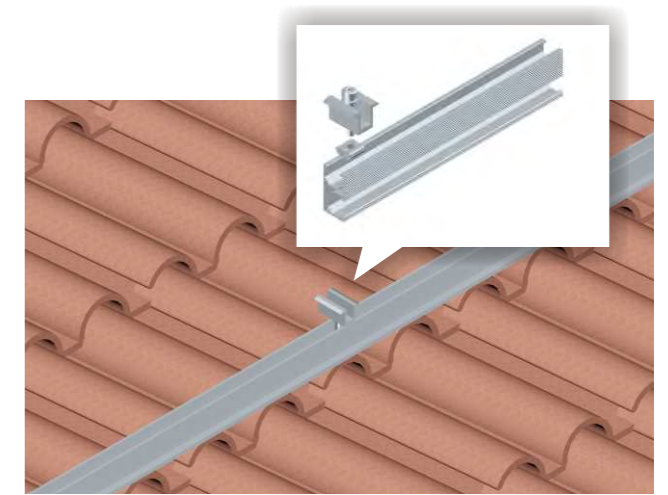

Step 6:
Fix the 1st mid clamp but not tighten at the location as specified in the drawing

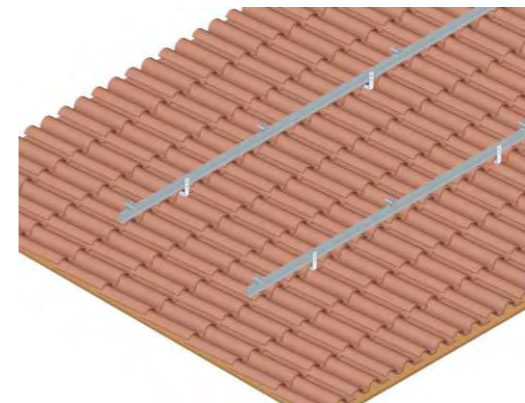

Step 7:
Fix but not tighten all the end and mid clamps

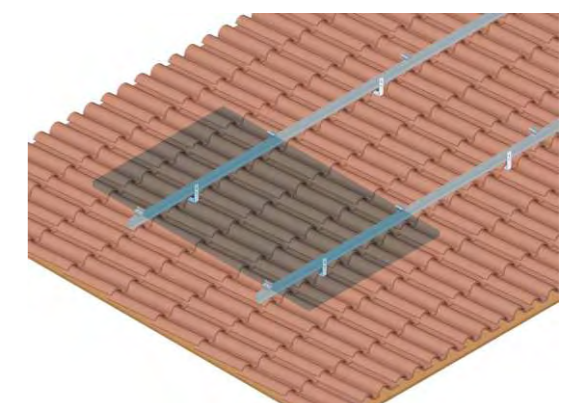

Step 8:
Mount the 1st module and tighten the screws with specified torques

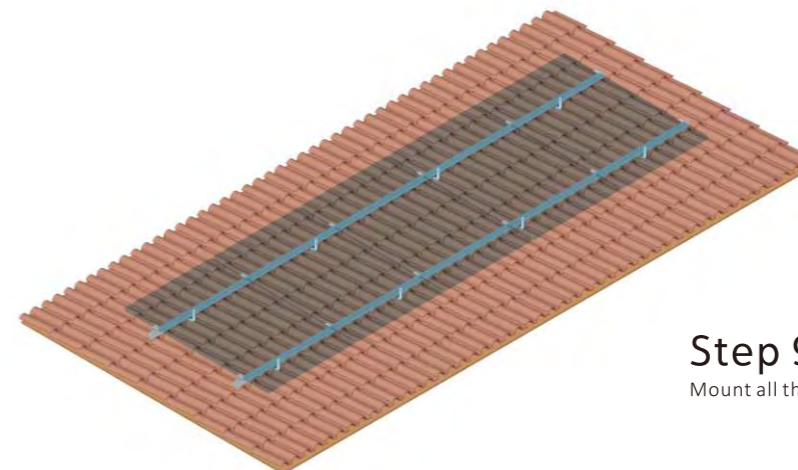

Step 9:
Mount all the modules

RC Roof Solution

Traditional 10° / 20° / 30°+

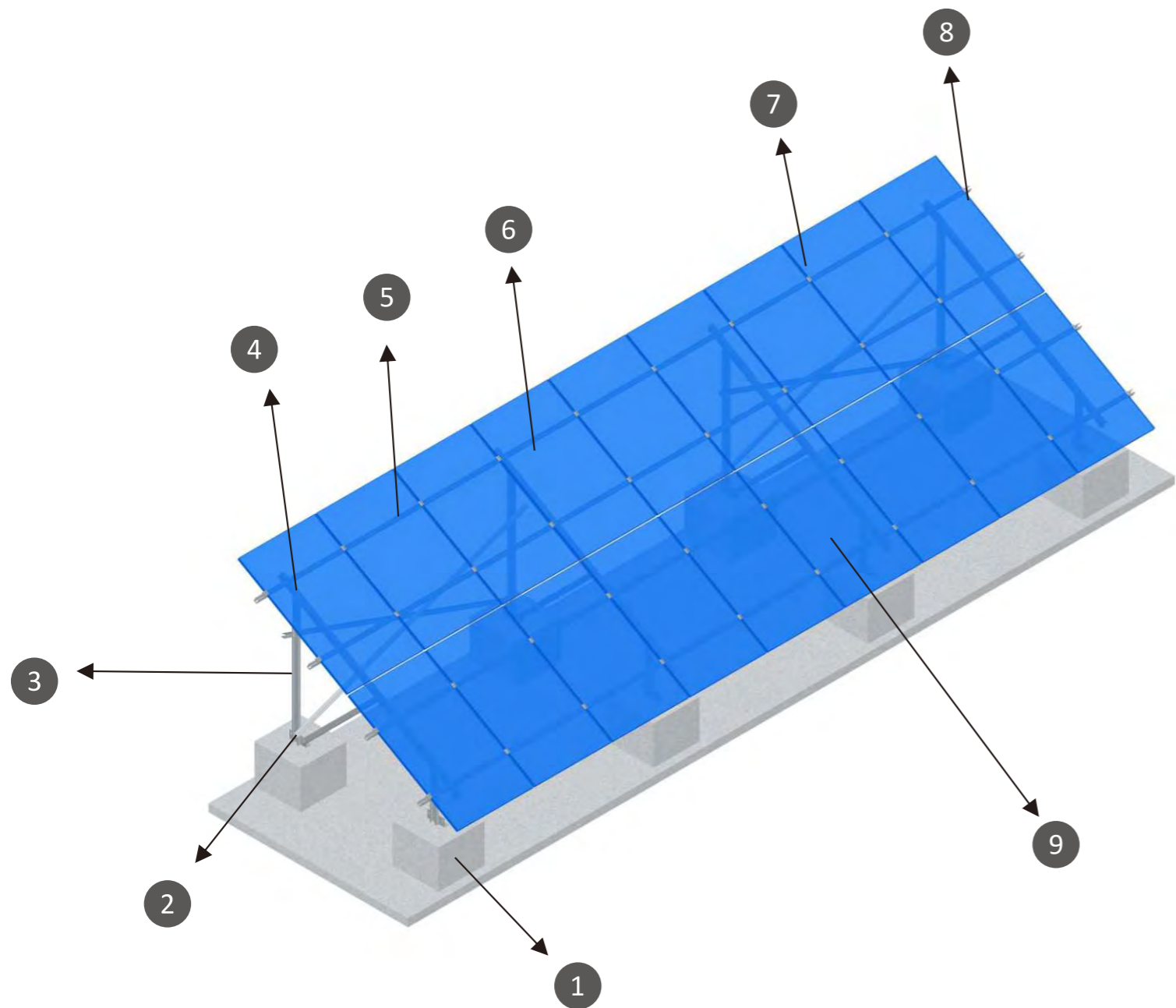

- | | | | | | |
|---|--|-------------------------|---|--|----------------|
| 1 | | Pre-cast Concrete Stump | 2 | | Fixation Plate |
| 3 | | Vertical Pole | 4 | | Main Beam |
| 5 | | Rail | 6 | | Rail Joiners |
| 7 | | Mid Clamp | 8 | | End Clamp |
| 9 | | Solar Module | | | |



RC Roof Solution

Counter Weighed 10° / 20° / 30°+

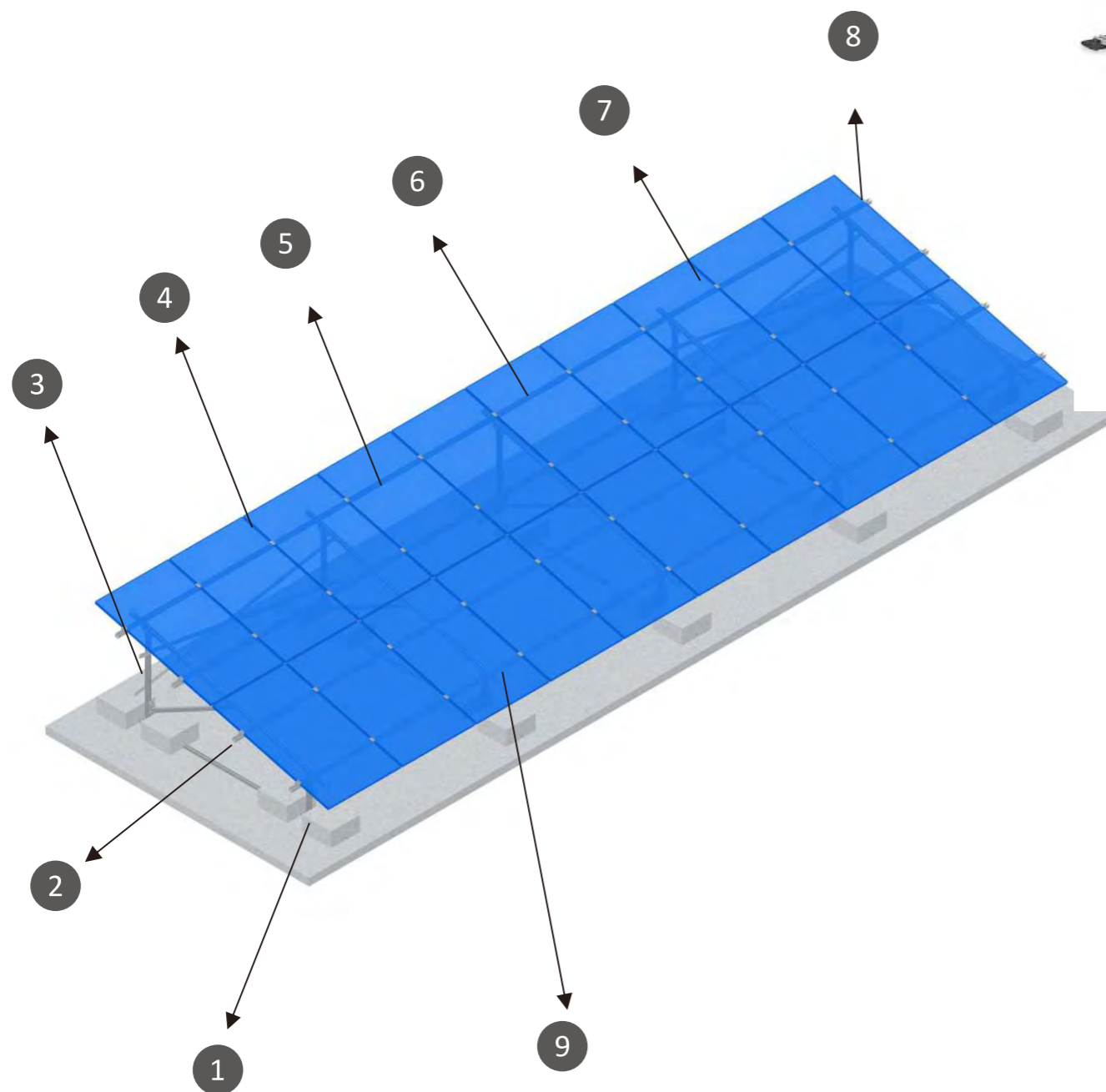

- 1 Sit-on Concrete Stumps
- 2 Base Rail
- 3 Vertical Pole
- 4 Main Beam
- 5 Rail
- 6 Rail Joiners
- 7 Mid Clamp
- 8 End Clamp
- 9 Solar Module

RC Roof Solution

Simple Installation Process

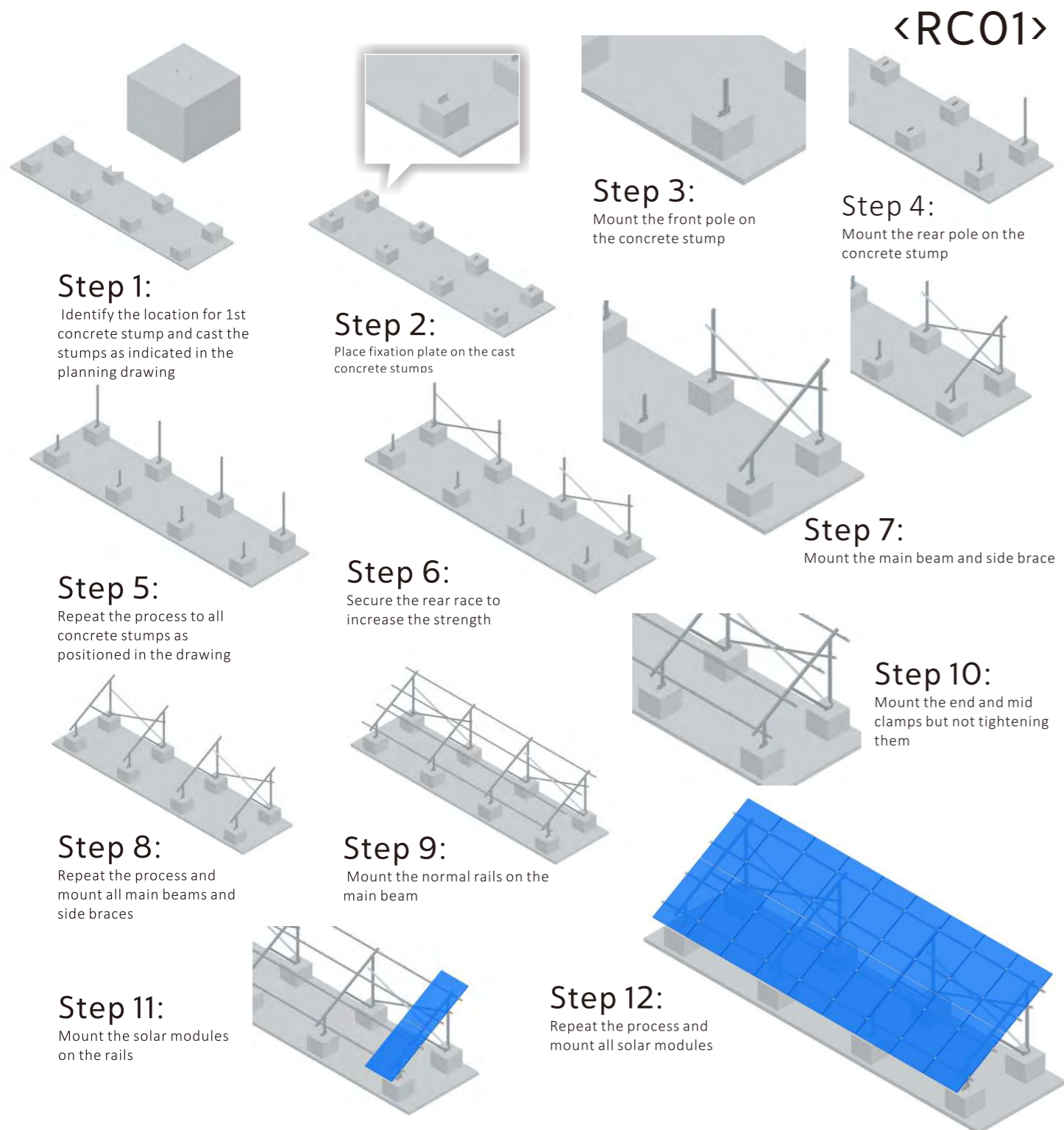

<RC01>

<RC02>

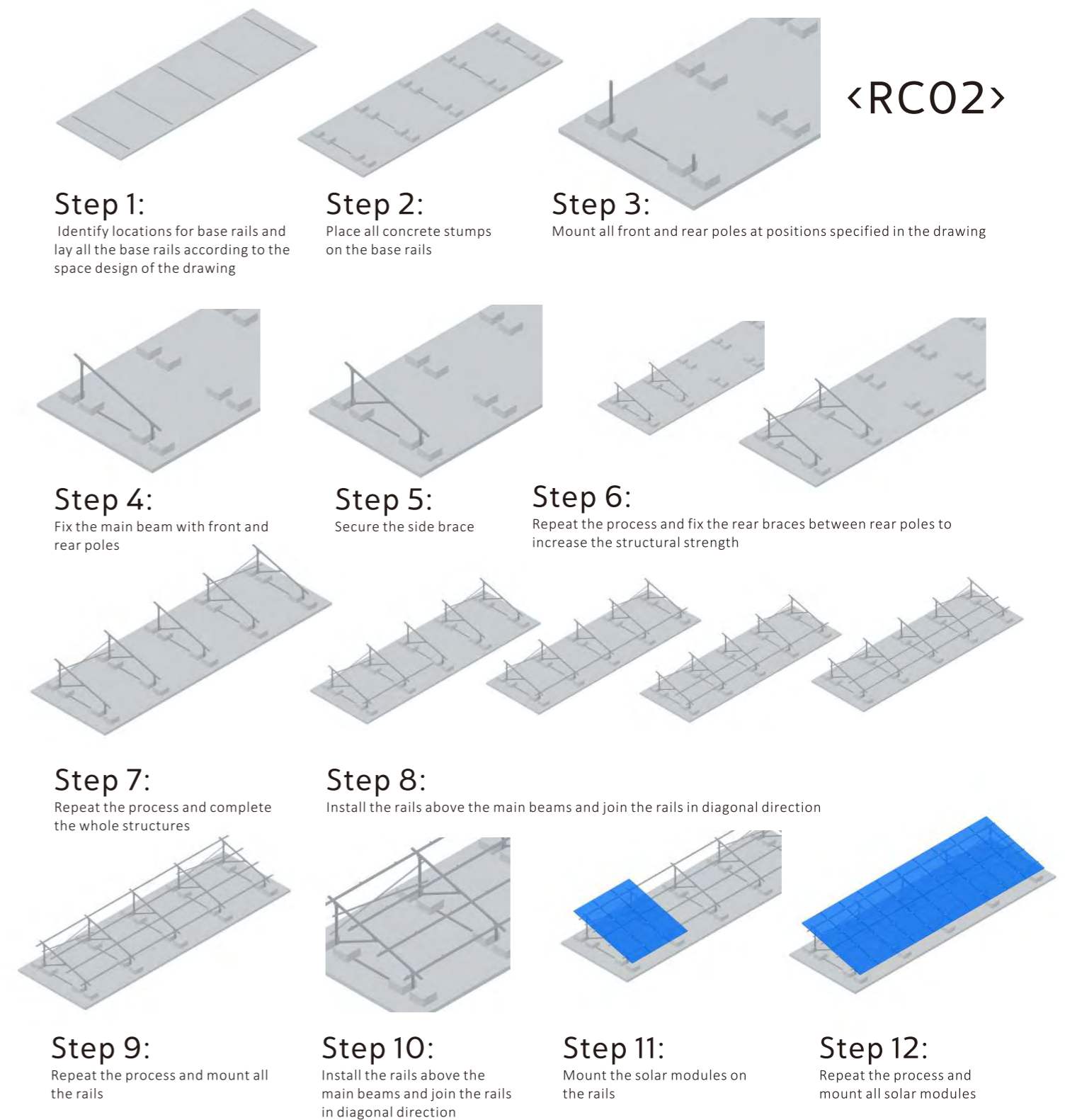

Ground Mounted Solar Racking

Type A: 10° / 20° / 30°+

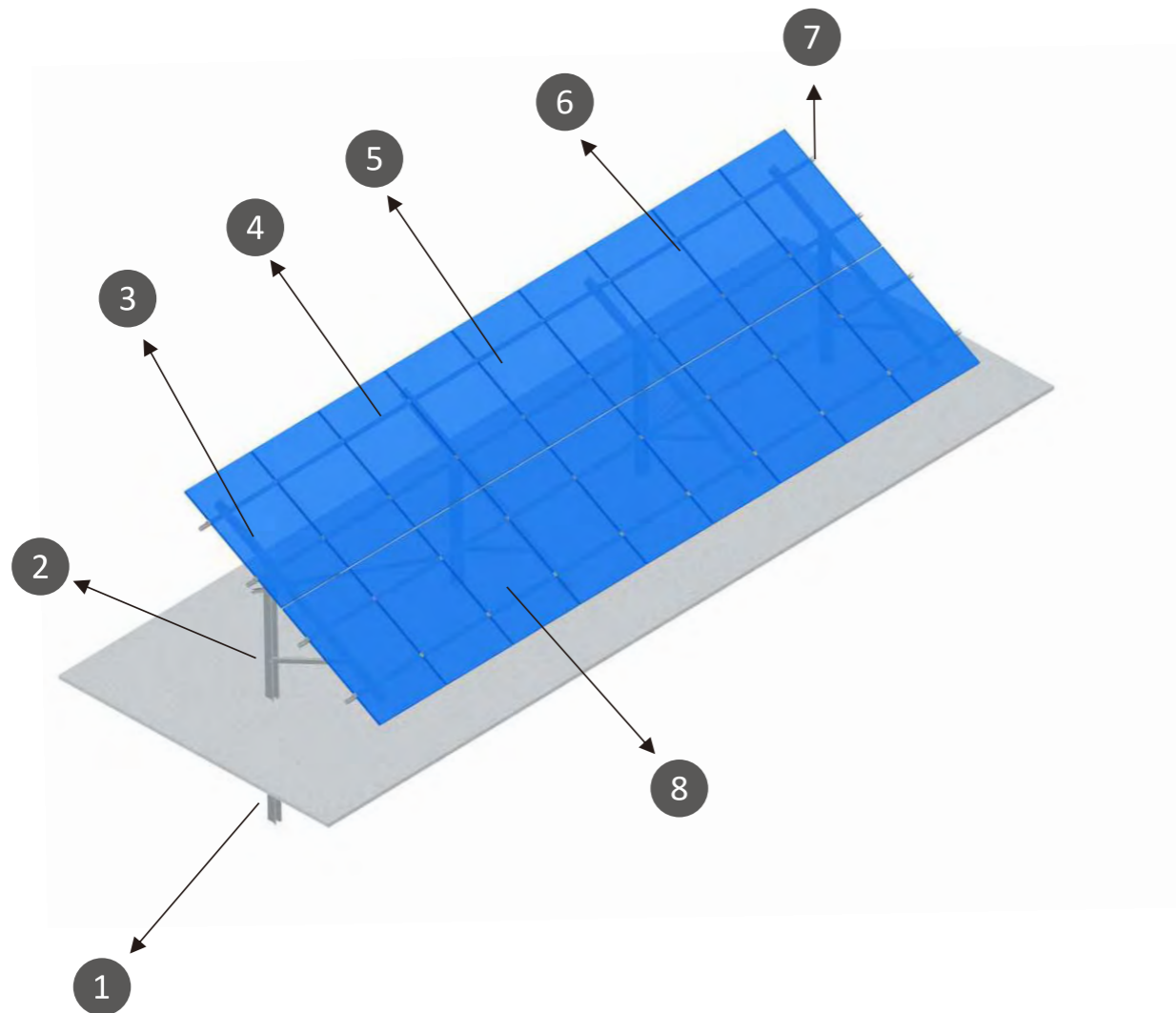

- | | | | | | |
|---|--|-----------------------|---|--|-----------------------|
| 1 | | Main Pole underground | 2 | | Main Pole aboveground |
| 3 | | Main Beam | 4 | | Rail |
| 5 | | Rail Joiners | 6 | | Mid Clamp |
| 7 | | End Clamp | 8 | | Solar Module |

Ground Mounted Solar Racking

Type B: 10° / 20° / 30°+

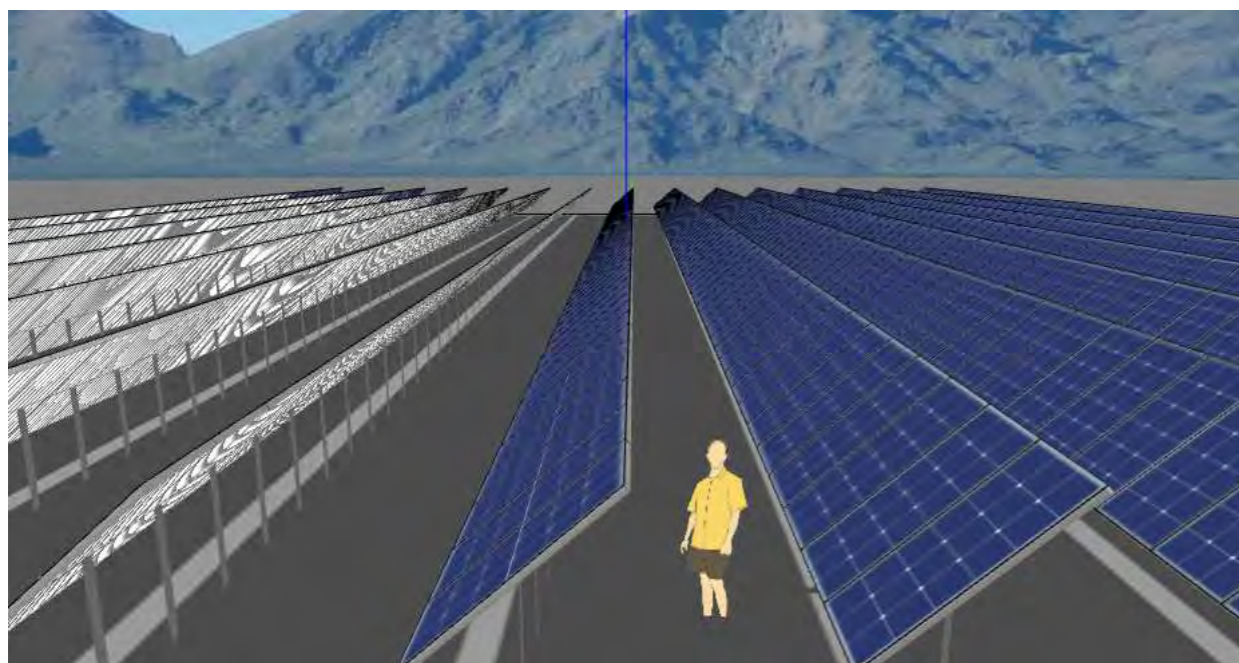
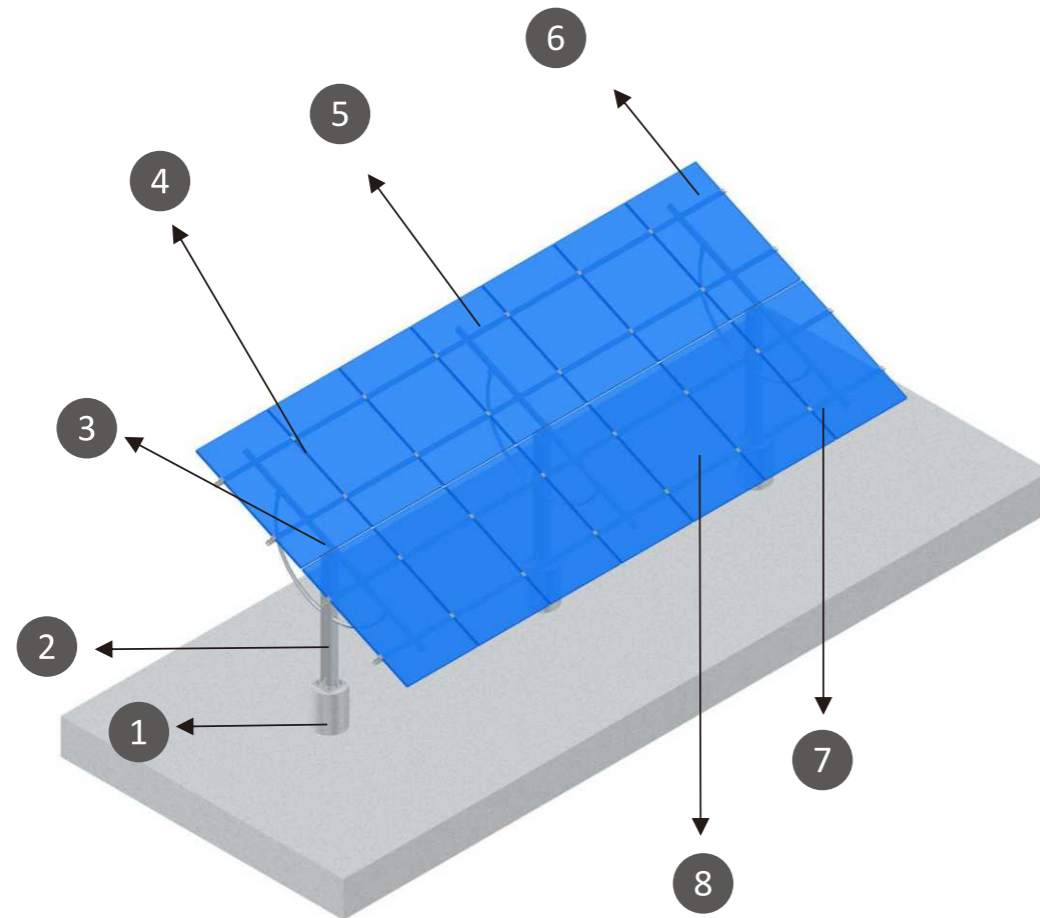

- | | | | | | |
|---|--|-----------------------|---|--|-----------------------|
| 1 | | Main Pole underground | 2 | | Main Pole aboveground |
| 3 | | Main Beam | 4 | | Rail |
| 5 | | Rail Joiners | 6 | | Mid Clamp |
| 7 | | End Clamp | 8 | | Solar Module |

Ground Mounted Solar Racking

Simple Installation Process

<G01>



Step 1:
Identify the location for 1st main pole and install the pole according to the drawing



Step 2:
Install all the poles at locations as specified in the planning drawing



Step 3:
Mount the main beam with side support on the main pole



Step 4:
Repeat the process and complete the 2nd pole structure



Step 5:
Secure the rear brace and increase the structural strength



Step 6:
Repeat the process and mount all pole structures with layout designed in the drawing



Step 7:
Secure the normal rail on the main beams

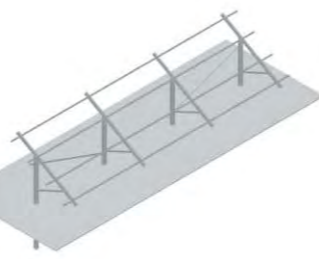

Step 8:
Repeat the process and mount all the rails



Step 9:
Mount the end and mid clamps but not tightening them

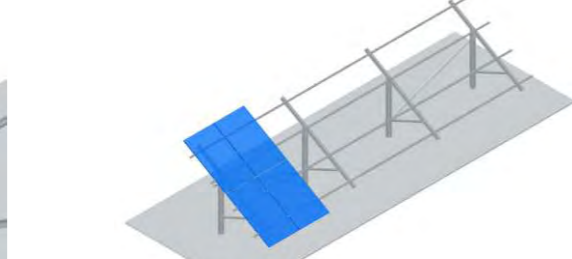

Step 10:
Mount the solar modules on the rails

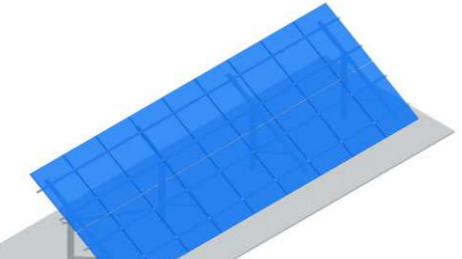

Step 11:
Repeat the process and mount all solar modules

<G02>



Step 1:
Identify the location for 1st main pole and install the pole according to the drawing



Step 2:
Install all the poles at location as specified in the planning drawing



Step 3:
Mount the main beam with side support on the main pole



Step 4:
Repeat the process and complete the main structure



Step 5:
Mount the adjustable structure with main beam on the main pole



Step 6:
Repeat the process and complete the full adjustable structure installation



Step 7:
Secure the normal rail on the main beams



Step 8:
Repeat the process and mount all the rails

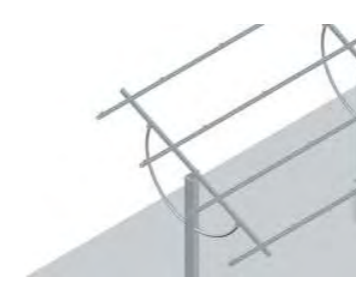

Step 9:
Mount the end and mid clamps but not tightening them

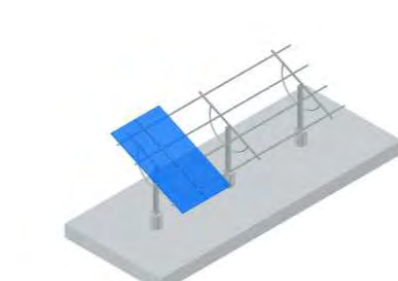

Step 10:
Mount the solar modules on the rails

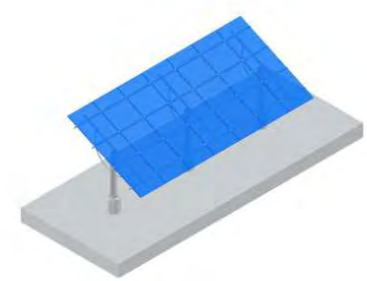

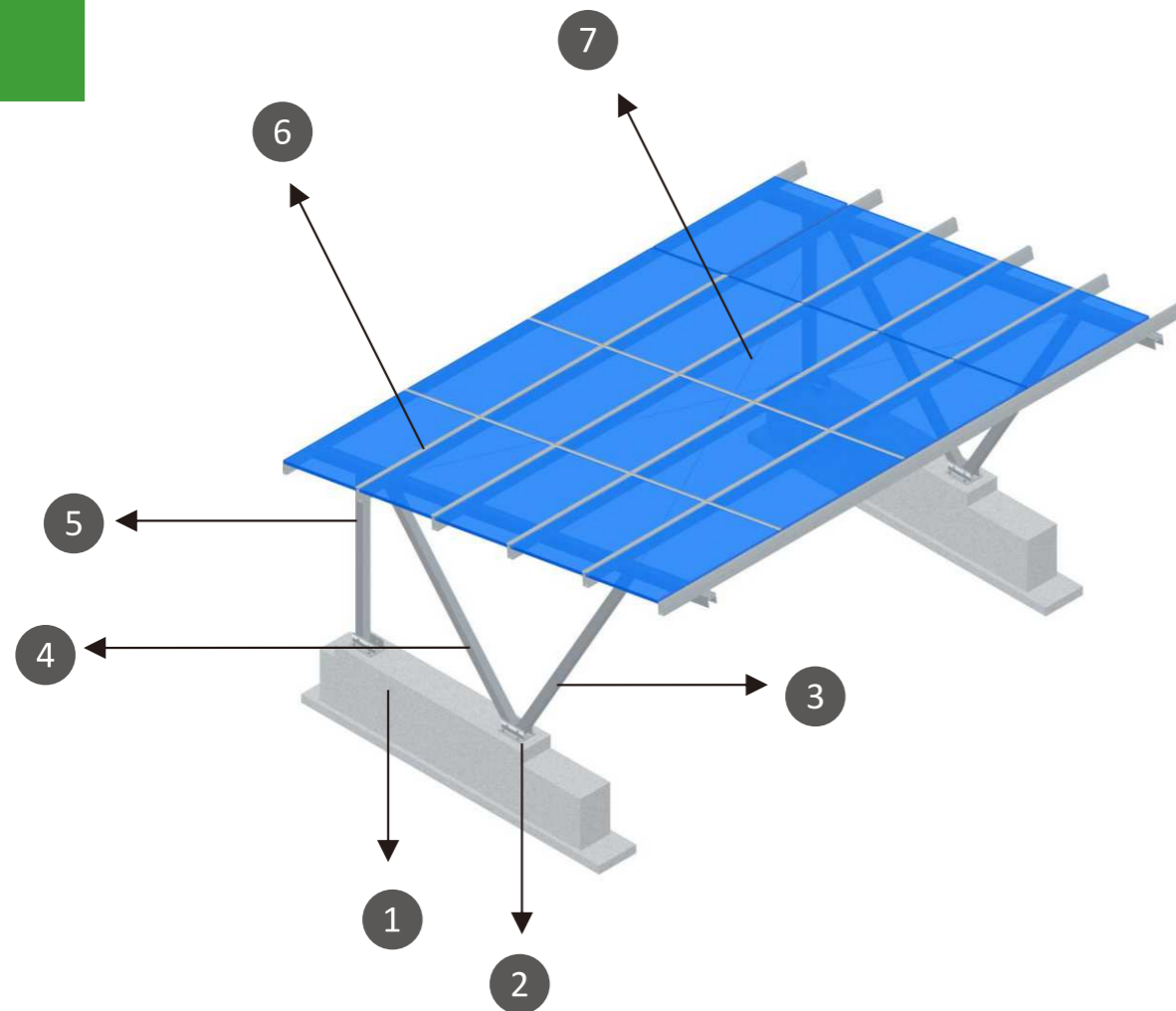

Step 11:
Repeat the process and mount all solar modules

Solar Carport Solution

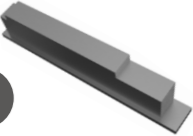



- 

1 Concrete Base
- 

2 Base Plate
- 

3 Front Pole
- 

4 Secondary Front Pole
- 

5 Rear Pole
- 

6 Main Beam
- 

7 Solar Module



Step 1:
Identify the location for the first concrete base and cast the concrete base as designed in the shop drawings



Step 2:
Repeat the process and set out the concrete base at distance and location specified in the drawing



Step 3:
Mount the main support structure with tightening rod on top



Step 4:
Install the main beam with rails on the main structure

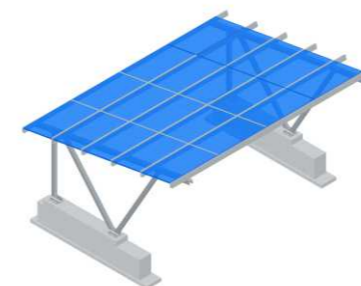

Step 5:
Mount the solar modules and complete the installation

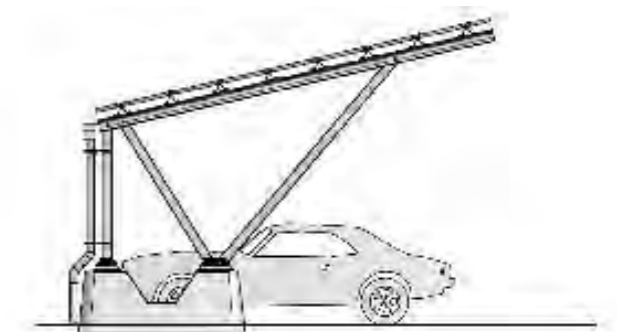

B1: 1 Row Vehicle Arrangement

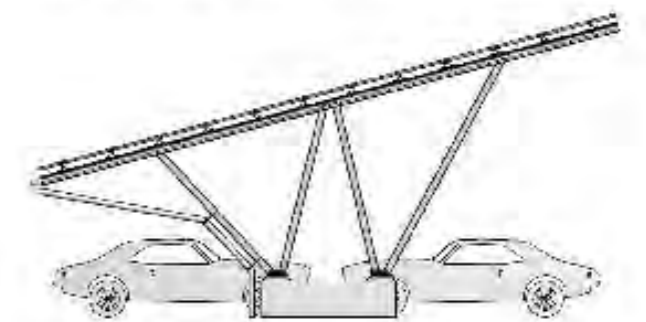

B2: 2 Row Vehicle Arrangement

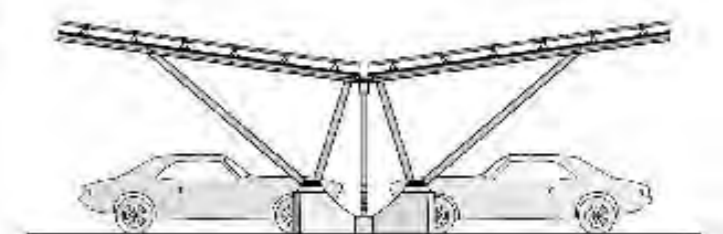

B3: 2 Row Vehicle Arrangement (North/South Facing)

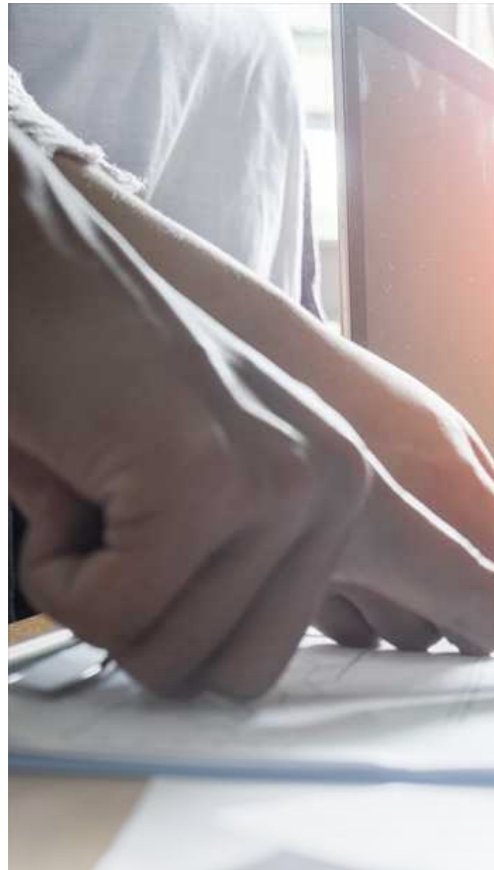

Professionalism

We have in-house engineers who are able to do structural designs to meet different standards of different countries by using the software SAP2000.



The working procedures are as follows:

- Alumsolar will issue a standard questionnaire to the customer
- Customer shall complete the questionnaire and furnish PVSolver required documents, include but not limited to module datasheet, maximum wind speed, applied standards, roof profile details, soil report, etc
- Alumsolar will work out basic design with simple prelim calculations for customer review
- Detailed calculation book will be provided upon confirmation of the project

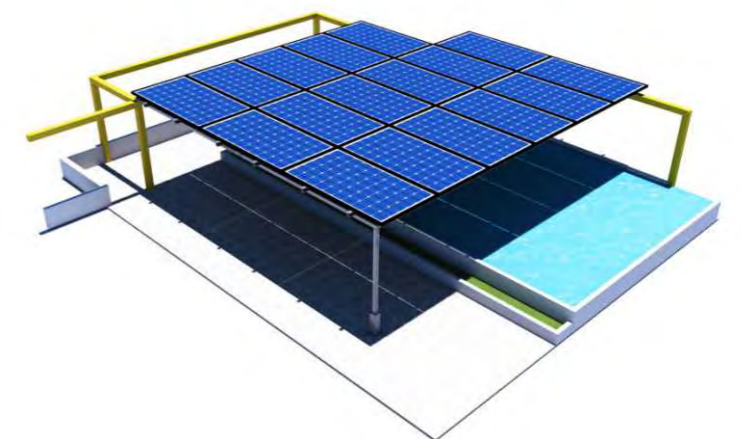
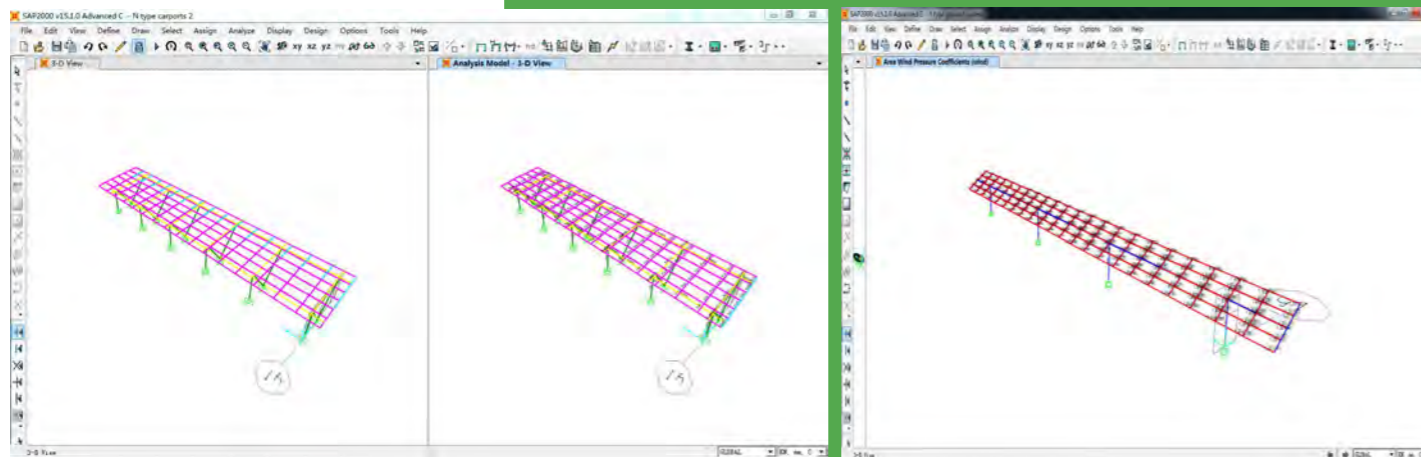

Products

< Seam Clamp for Metal Roofs >



< Hooks for Tile Roofs >



< Rails >

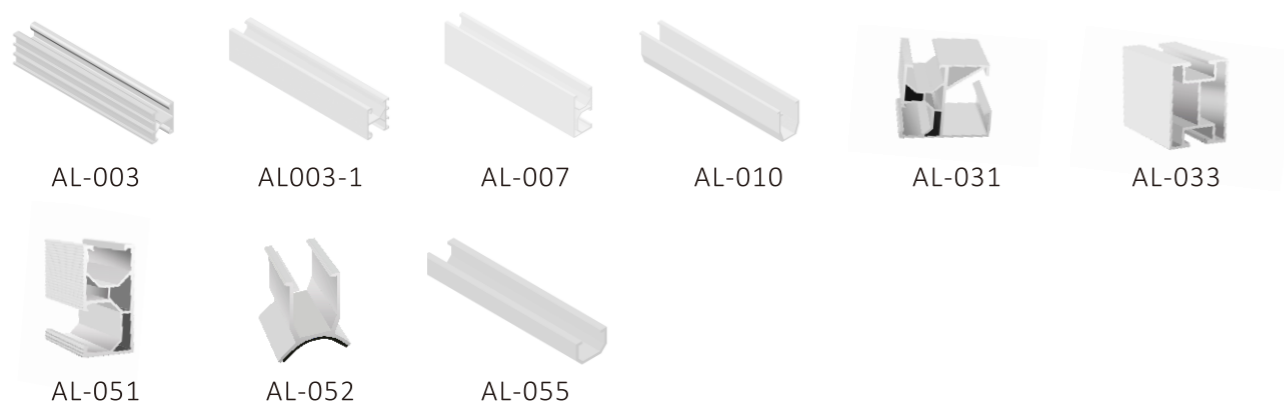

< Mid and End Clamps >



< Parts and Accessories >

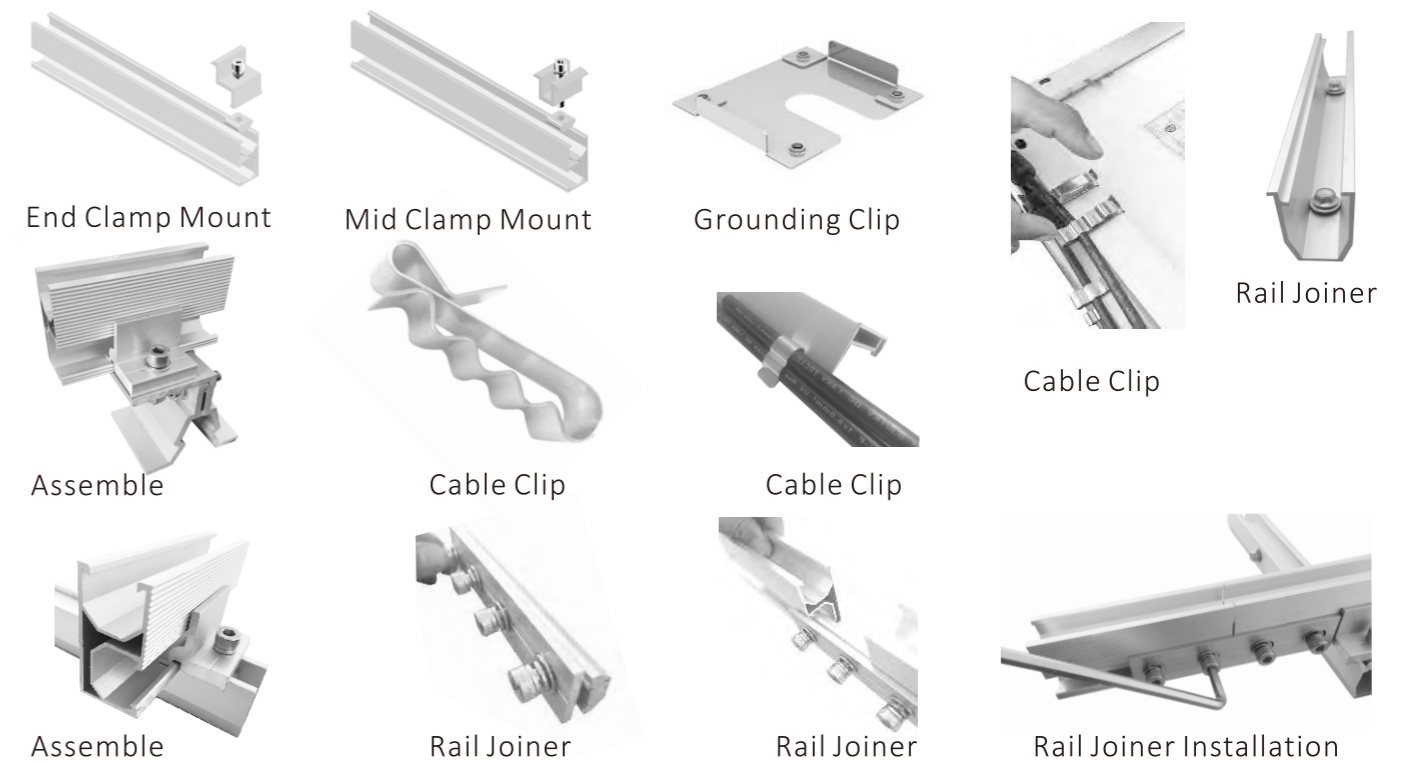



Products



Rail



Rail Joiner



Anchor Bar



Rail



Pile



Rail

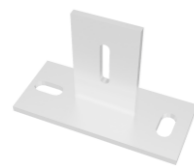

Base Plate



Vertical Pole



Base Plate



Rail



Rail



Adjustable Pole



Vertical Pole



Rail



Rail

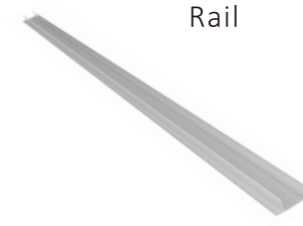

RC-026



Pole

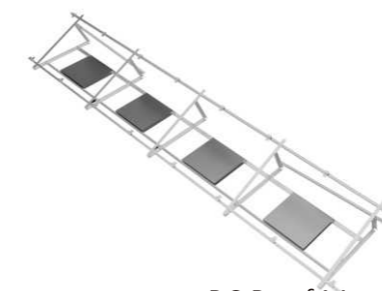

RC Roof Mounting



Rail



Rail



RC-026



Adjustable Pole



Pole Connection



Base Plate



Base Plate

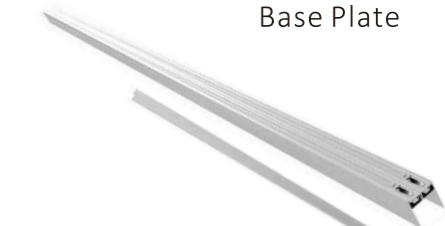

RC-026



Rail



Ballast Tray Type for RC Roof



Connection



Base Plate



Connection



project portfolio



Project Location: Shanghai, China
Capacity: 60MWp
Completion Year: 2018
Type: Concrete Roof Mounted



Project Location: Shanghai, China
Capacity: 4.3MWp
Completion Year: 2016
Type: Concrete Roof Mounted



Project Location: Tuas, Singapore
Capacity: 1MWp
Completion Year: 2017
Type: RC Roof Mounted



Project Location: Singapore
Capacity: 221Wp
Completion Year: 2017
Type: Metal roof Mounted



Project Location: Singapore
Capacity: 1.6MWp
Completion Year: 2017
Type: Metal roof Mounted



Project Location: Shiga-ken, Japan
Capacity: 2MWp
Completion Year: 2015
Type: Metal Roof Mounted



Project Location: Iloilo, Philippines
Capacity: 1.9MWp
Completion Year: 2016
Type: Metal roof Mounted



Project Location: Cebu, Philippines
Capacity: 2.5MWp
Completion Year: 2017
Type: RC Roof Mounted



Project Location: Iloilo, Philippines
Capacity: 1.9MWp
Completion Year: 2016
Type: Metal roof Mounted



Project Location: Cebu, Philippines
Capacity: 2.5MWp
Completion Year: 2017
Type: Metal roof Mounted



Project Location: Africa
Capacity: 1.6MWp
Completion Year: 2015
Type: Metal Roof Mounted



Project Location: USA
Capacity: 2.5MWp
Completion Year: 2015
Type: Ground Mounted



Project Location: Shanghai, China
Capacity: 60MWp
Completion Year: 2018
Type: Ground Mounted



Project Location: Klang, Malaysia
Capacity: 426kWp
Completion Year: 2016
Type: Metal roof Mounted



Project Location: Tuas, Singapore
Capacity: 1MWp
Completion Year: 2017
Type: Metal roof Mounted



Project Location: Singapore
Capacity: 221Wp
Completion Year: 2017
Type: Metal roof Mounted



Project Location: Singapore
Capacity: 1.6MWp
Completion Year: 2017
Type: Metal roof Mounted



Project Location: Shiga-ken, Japan
Capacity: 2MWp
Completion Year: 2015
Type: Ground Mounted



Project Location: Africa
Capacity: 1.6MWp
Completion Year: 2015
Type: Ground Mounted



Project Location: USA
Capacity: 2.5MWp
Completion Year: 2015
Type: RC roof Mounted

Nature, the gentlest mother

_____Emily dickinson



Alumsolar Group



Address: No.7 Industry zone, Jiutoushan Road, Yufeng district, Liuzhou city, Guangxi province, China

Tel: +86 186 0217 5688

Whatsapp: +86 186 0217 5688

Web: <https://alumsolar.wixsite.com/alumsolar>